

For additional information see Technical Tips on pages BC1-BC2.

Dimensions
 Millimeters (Inches)

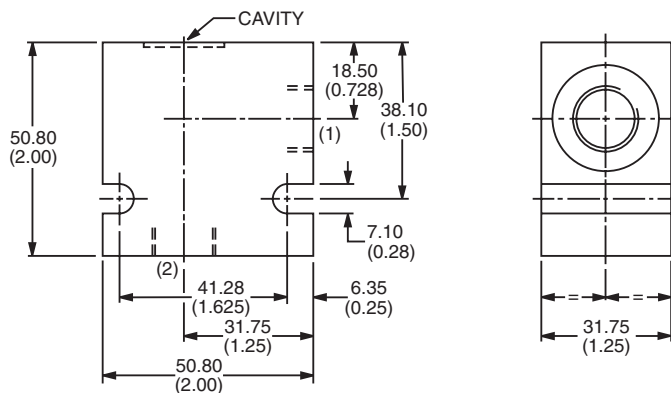

Ordering Information

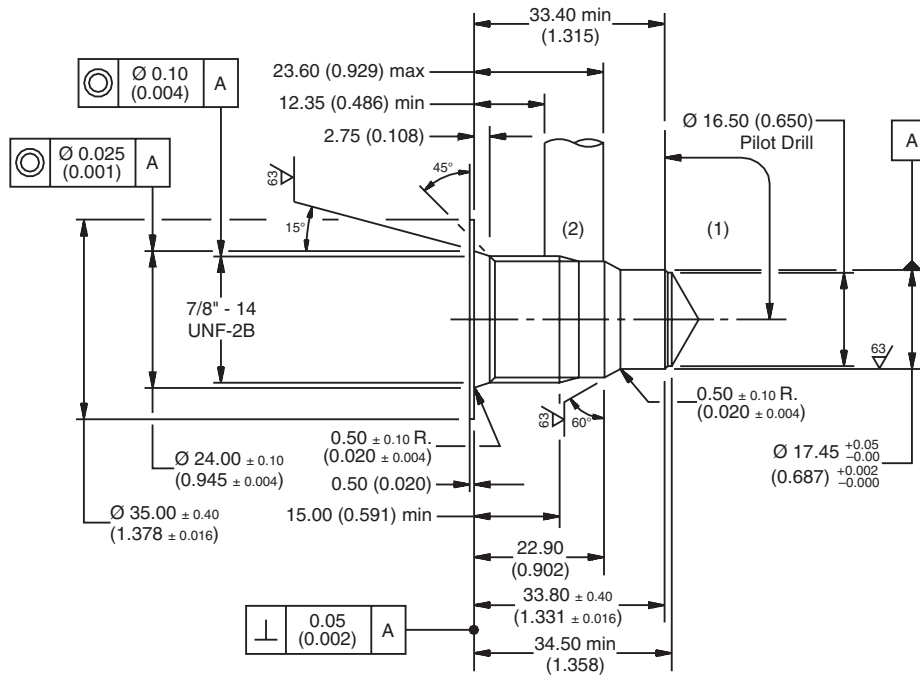
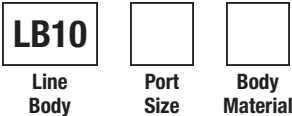

Code	Port Size
543	1/2 SAE

Code	Body Material
A	Aluminum
S	Steel

Cavity Tooling For 2R	
Pilot Drill	Ø
Step Drill	
Reamer (Alum)	
Reamer (Steel)	
Counterbore	
Tap	